

Main Features:-

- ◆ 2pc Design Stainless Ball Valve
- ◆ ISO 5211 Direct Mount
- ◆ ANSI 150 Flanged
- ◆ TFM1600 seats and Viton Seals
- ◆ -10C to +180C Temperature Rating PN63

*Temperature and pressure determined by valve body, seat etc.

Suitable Applications & Approvals:



INDUSTRY

OIL

WATER

GAS



SERIES: 10119

MANUFACTURER:

AVOL
INDUSTRIAL VALVES

SIZE	CODE	D	F	G	L	W	H	S	S1	T	KG	NM	ISO	STEM
1/2"	10119-04	15	1.6	9.6	108	165	87.4	46.5	53.5	3.1	2.2	5	-	9
3/4"	10119-05	20	1.6	11.2	117	162	91.4	51.5	59.5	5	2.6	8	F05	9
1"	10119-06	25	1.6	12.7	127	162	98.4	57.5	68.3	6	3.7	10.5	F05	11
1 1/2"	10119-08	40	1.6	15.9	165	203	108.4	76.5	90	6	6.9	20.5	F07	14
2"	10119-09	50	1.6	17.5	178	203	110.8	83.5	92.3	6.5	9.7	31	F07	14
3"	10119-11	80	1.6	22.3	203	323	180	129.5	129.5	7	19.6	62	F10	17
4"	10119-12	100	1.6	22.3	230	323	194.2	145	145	7	27.3	97	F10	17
6"	10119-14	150	1.6	23.9	394	415	240	175	221.3	7.1	62	210	F12	27
8"	10119-16	200	1.6	28.6	457	920	304	-	-	-	92	600	F14	36

VALVE DIMENSIONS

DIMENSIONAL DRAWING OF VALVE

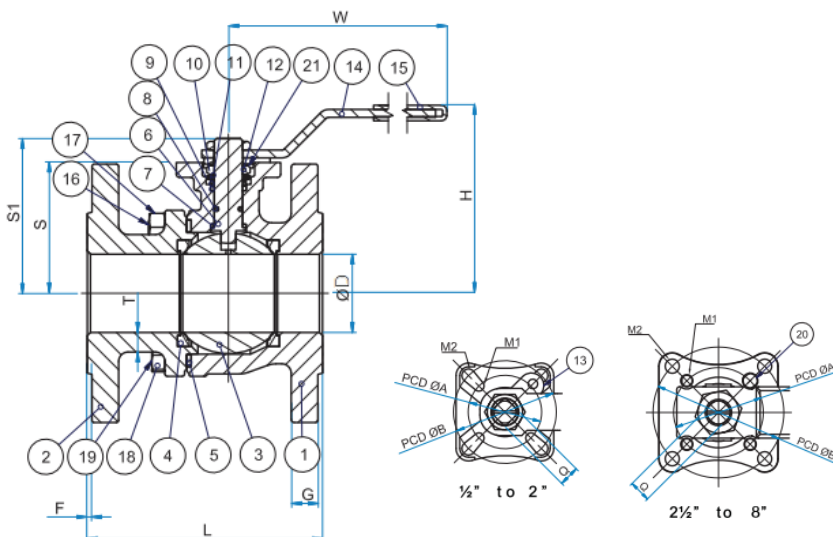

MATERIALS OF CONSTRUCTION

BODY	CF8M SS
BALL	CF8M SS
BODY SEAT	TFM 1600
STEM	316 SS
ORINGS	VITON
PRESSURE	CLASS 150
TEMP	-20 to +180C

T +44 (0)1386 552369

W www.allvalves.co.uk

E sales@allvalves.co.uk

F +44 (0)1386 554227